

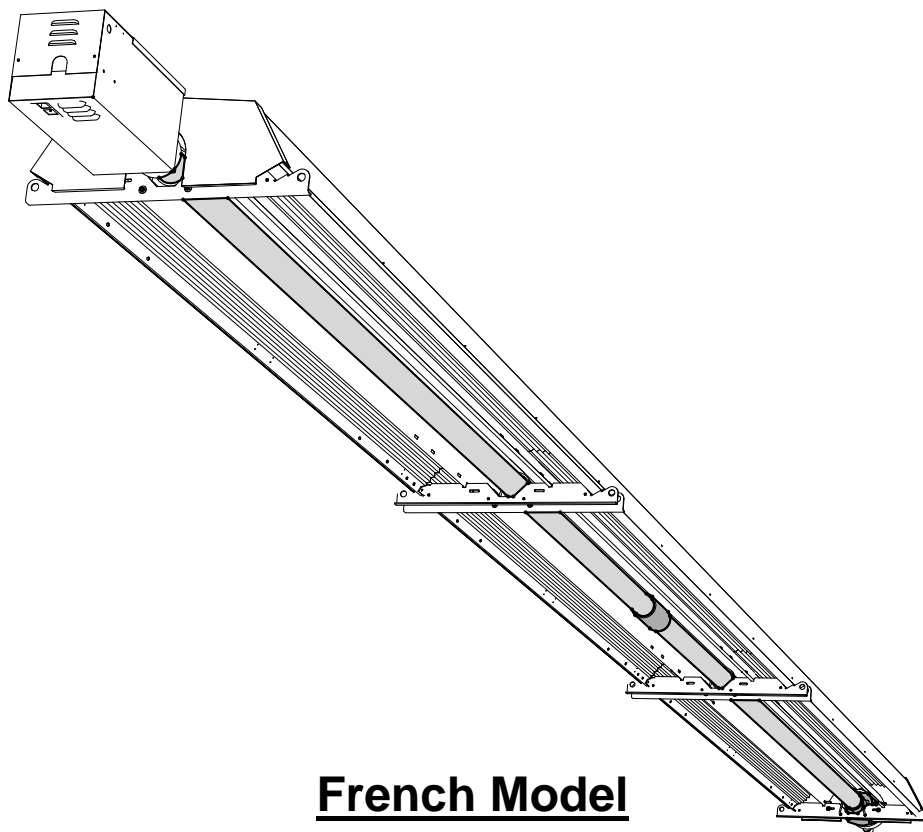

High Efficiency Radiant Tube Heaters
BTwin™ BTLH2R25
Installation, maintenance and user



French Model

**Avertissement
Warning**

Please read this document carefully before commencing the installation and leave it with the user after installation. The document accompanying each unit is meant for the installer and the user. This document contains instructions for installing the heater and flue system and describes in particular how to carry out gas connection & electrical connection. Subcontractors must also receive this document.

Système de
management
certifié



 **NORTEK™**
GLOBAL HVAC

INDEX

1	RULES	P 4
2	TECHNICAL SPECIFICATIONS	P 5
3	DIMENSIONS	P 6
4	APPLIANCE ASSEMBLY	P 7
	a/ Packaging	
	b/ Reflector/convector assembly	
	c/ Tubes preparation	
	d/ Tubes assembly	
	e/ Burner, extractor and sleeves assembly	
	f/ Mounting of anti-rotation strap	
5	HANGING AND FIXING THE UNIT	P 13
6	CLEARANCES	P 15
	a/ Distances to unprotected combustible materials	
	b/ Minimum recommended mounting height	
7	EVACUATION OF COMBUSTION PRODUCTS	P 16
	Type A	
	Type B	
8	INSTALLATION METHOD & CONNECTIONS	P 19
	a/ Electrical connection	
	b/ Flue system	
	c/ Gas connections	
	d/ Option 'Failure signal transmission'	
9	TEMPERATURE REGULATION	P 21
10	PROGRAMMING	P 21
11	SETTING UP	P 21
12	MAINTENANCE	P 22
13	GAS CHANGE	P 24
14	FAULTS – POSSIBLE CAUSES - SOLUTIONS	P 25
15	ELECTRICAL SCHEMA	P 26
16	OPTIONS ON REQUEST	P 27
17	PARTS LIST	P 27

1 Rules

GÉNÉRAL CAUTION

- The installation will have to be **in compliance** with the norms in force and be carried out according to traditional rules by a skilled worker.
- The installer will have to refer to the various existing official documents according to the different stages that the installation will require (*see enclosure 1 at the end of this document*).
- The radiant tubes are CE certified and approved for use in many countries. In order to meet the national requirements only appropriate models should be used (in case of doubt, please contact us). The guarantee of conformity to regulations and standards does not apply to units designed for the French market but installed in foreign countries.
- The hotpoint of the heater amounts to more than 150°C. Please follow the directives of the competent authorities and respect the rules in force related to classified buildings or risky sites.
- The use is also prohibited in all the premises where there are corrosive fumes, even if there are small quantities of them, whose combination with water vapor and/or combustion products will entail abnormal deteriorations of the appliances. For example : chlorinated, sulphurous, ammonia or sodium products and diverse acid products
- All the requirements of the present regulation concerning ventilation and purifying shall be respected.

GUARANTEE LIMITS

Warranty is void if following instructions are not respected:

- The heaters are only designed for use in non-domestic applications with exclusion of any other utilization.
- Heaters must be installed inside the room, protected against humidity and bad weather conditions.
- Heaters must not be installed in atmospheres containing aggressive or corrosive vapors, even in small concentrations as the combination with combustion products can deteriorate the material (e.g. : chloride, sulphurous, ammonium, sodium and all kind of acid products)
- Storage of heater must be done carefully avoiding shocks and ensuring that heater is protected against bad weather conditions.
- The installation must be in accordance with these instructions
- Modification to this appliance is not authorized

2 Technical specifications

Model	Follow CE rules*	Unités	BTLH2R25
Nominal heat input		kW PCI	21
Nominal heat input		kW PCS	23,33
Combustion efficiency	>85	% PCI	>90
Radiation factor		-	0,69
Seasonal efficiency	>74%	%	>80%
NOX class NE 416	>1	-	3
Electrical connection		-	230/240V 50Hz single phase
Fuse protection		-	1 fusible 5A
Starting electrical power		VA	120
Functioning electrical power		VA	80
Combustion air & venting		-	A2, B22
Combustion air inlet opening type A & B		mm	Ø35
Flue outlet diaphragm diameter		mm	Ø48
Air pressure switch adjustment		Pa	64
Turbine discharge		mm	Ø133
Weight		kg	127

* In line with the ErP Regulation 2015/1188 and gas directive 2009/125/CE.

Adjustments in function of gas

Distributed gas	2H, 2E	2L, 2E	3P	3B
Gas category for France II2Er3+	x	x	x	x
Gas reference	G20	G25	G31	G30
Heat input (Hi) of gas reference 1013mbar	34,02MJ/m	29,25MJ/m	46,34MJ/kg	45,65MJ/kg
Nom. Inlet pressure mbar	20	25	37	29
Min. inlet pressure min mbar	17	20	25	20
Max. inlet pressure max mbar	25	30	45	35
BTLH2R25				
Ø injector mmx100	390	390	240	240
Pressure by injector mbar	11	16,5	RB*	RB*
Gas flow 15°C 1013mbar	2,22 m3/h	2,58 m3/h	1,63 kg/h	1,66 kg/h

* RB = blocked regulator

3 Dimensions

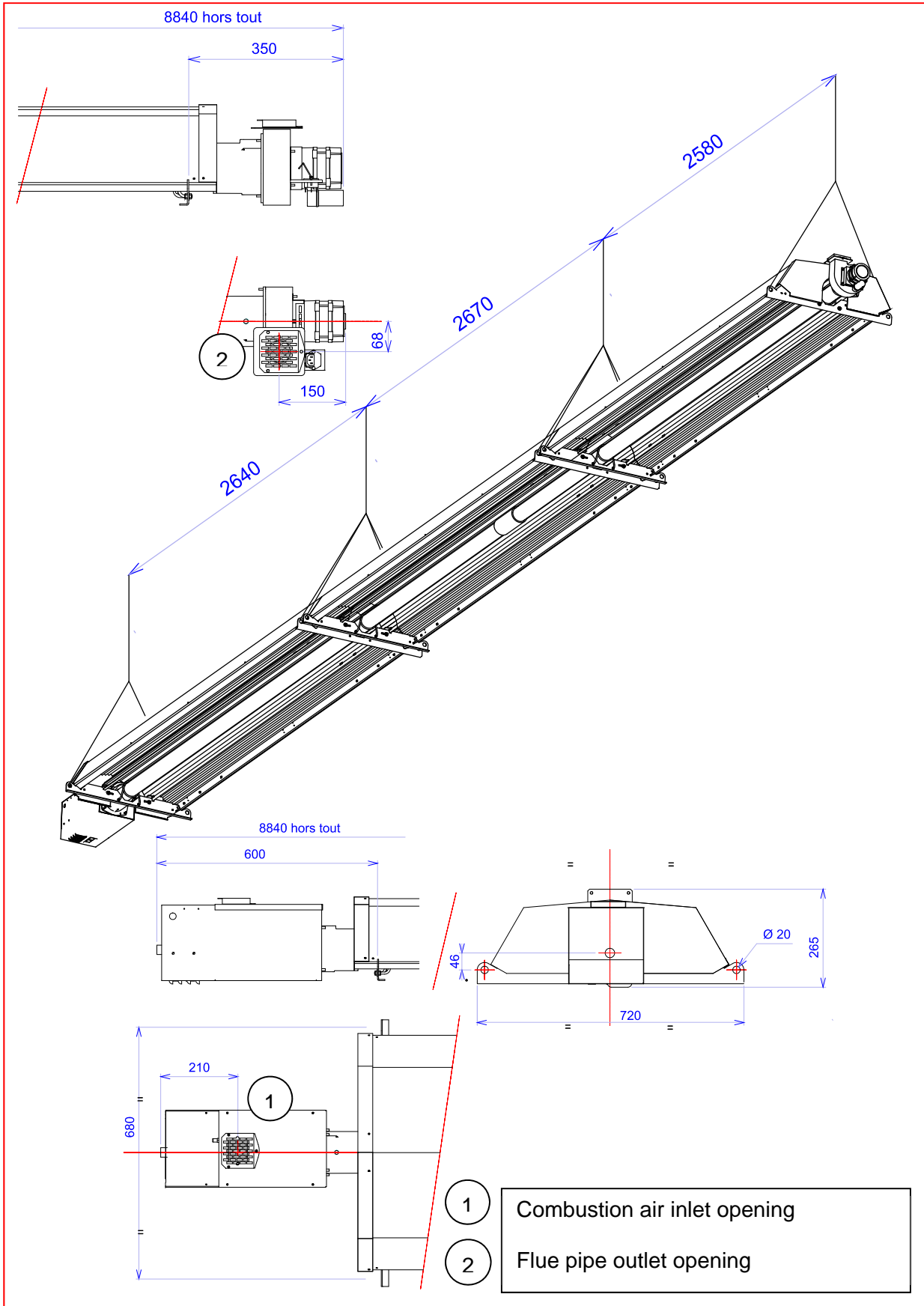

4 Appliance assembly

a/ Packaging

Qty	Designation	Reference
1	Carton containing burner / extractor	
1	Tube Ø76,1 – lg : 4 400 «burner side»	1030001
1	Tube Ø76,1 – lg : 3 750 «extractor side»	1030212
1	Carton containing reflector/convecter BTLH2R25 «burner side»	0712144
1	Carton containing reflector/convecter BTLH2R25 «central part»	0712145
1	Carton containing reflector/convecter BTLH2R25 «extractor side»	0712146
2	Turbulator tube Ø76.1 – lg : 1,00m	1003450
1	Turbulator tube Ø76.1 – lg : 2,00m	1003110

b/ Reflector/convecter assembly

Plan for hanging points under the roof following figure page 6.

Each part could be inclined between 0 and 30mm towards the burner, the total incline should be between 0 and 100mm max.

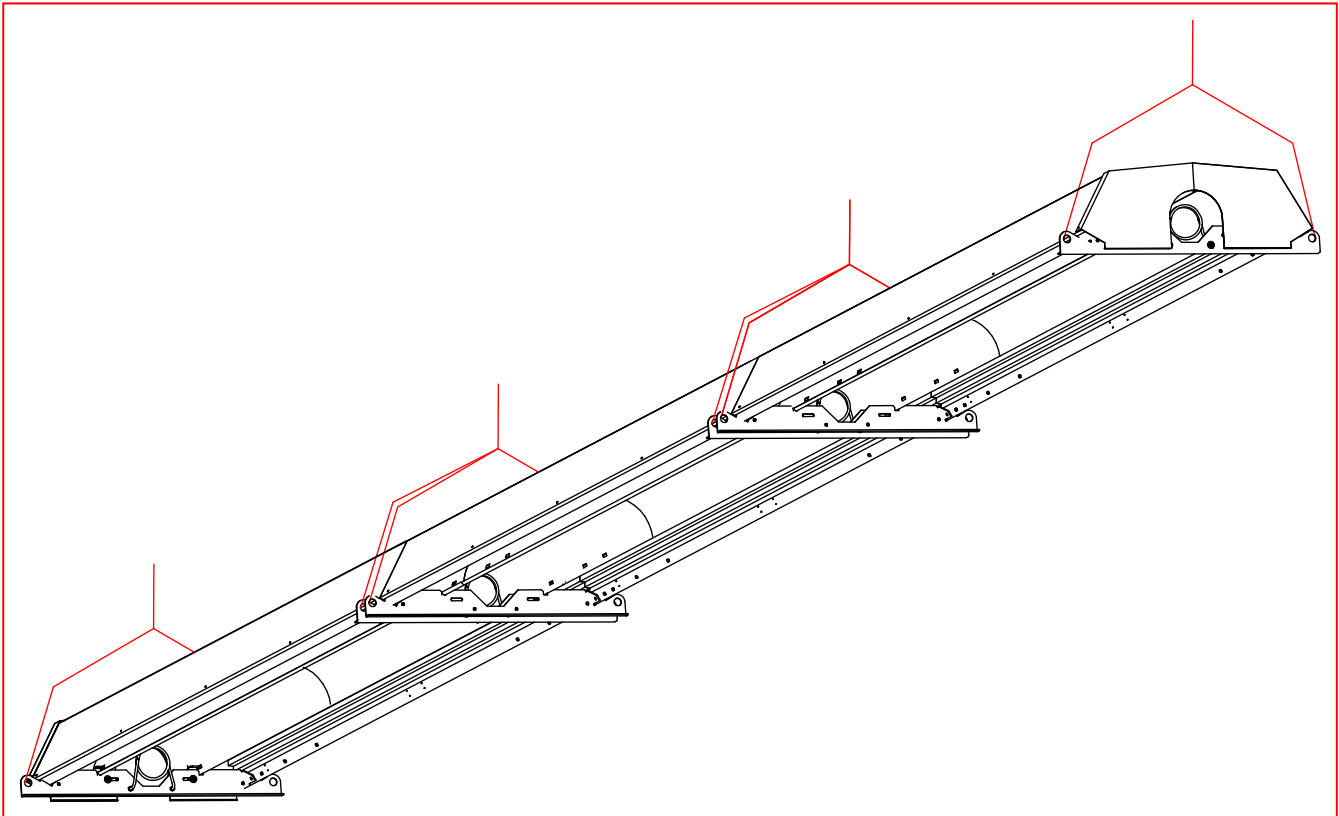

Reflectors and convectors sets (quantity = 3).

Each set has to be hanged under the roof one by one and assembled with the previous one.

Suspend under the roof the converter burner side (A).

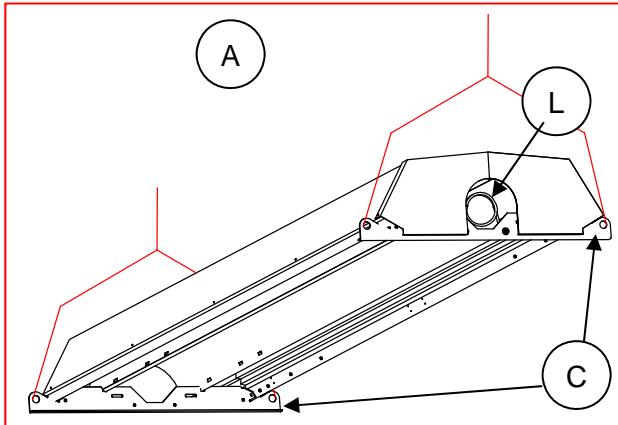

Suspend under the roof the converter central side (B).
The part (C) equipped with fixing rings (L) is positioned to the "burner side (A).

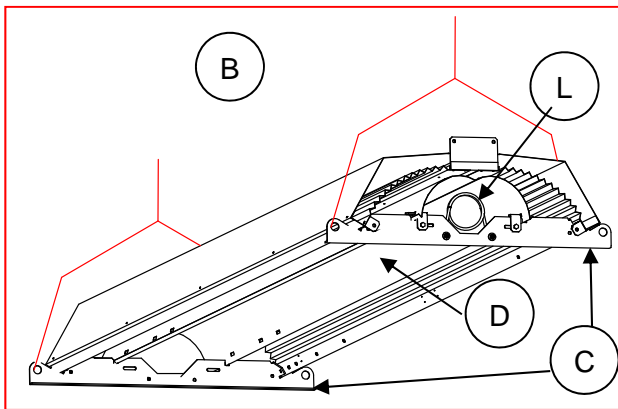

Reflectors (D) of each set have to be superimposed at the junction.

Put the fixing brackets of the reflectors (E) in open position.

Position the reflector (D) in the grooves of the traverse (C).

Put the fixation parts of the reflectors (E) in closed position and screw these parts in order to maintain the reflectors (D).

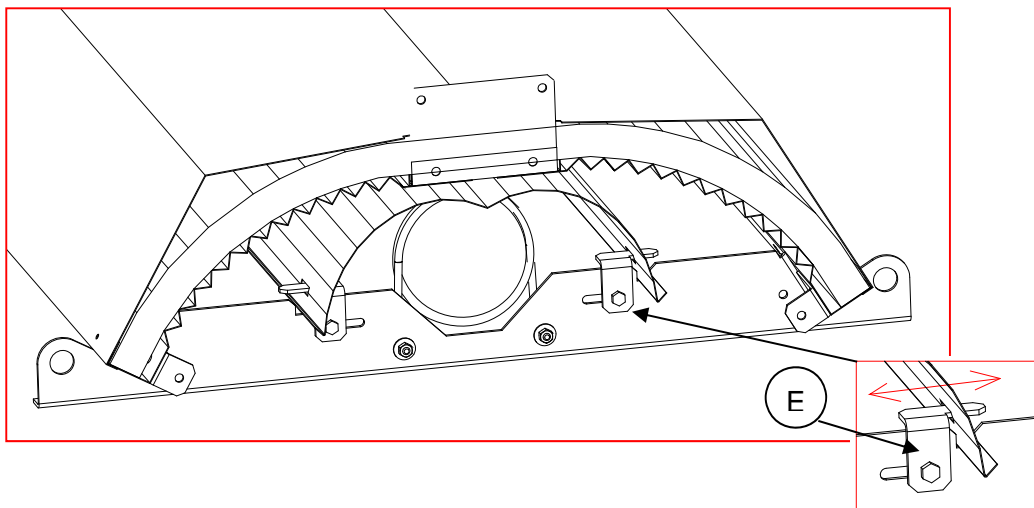

The assembly is made unmovable by 4 screws, 4 washers and 4 nuts (F and G).

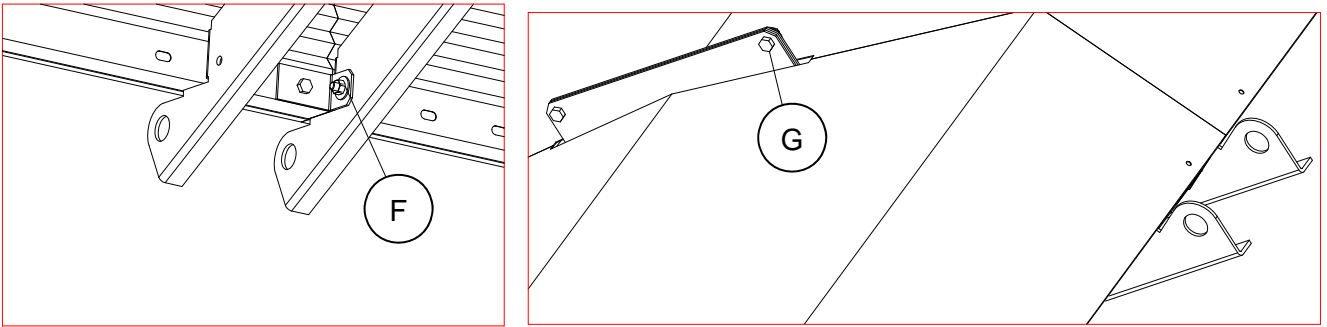

Hereunder, the 2 sets reflectors/converters (A and B) assembled.

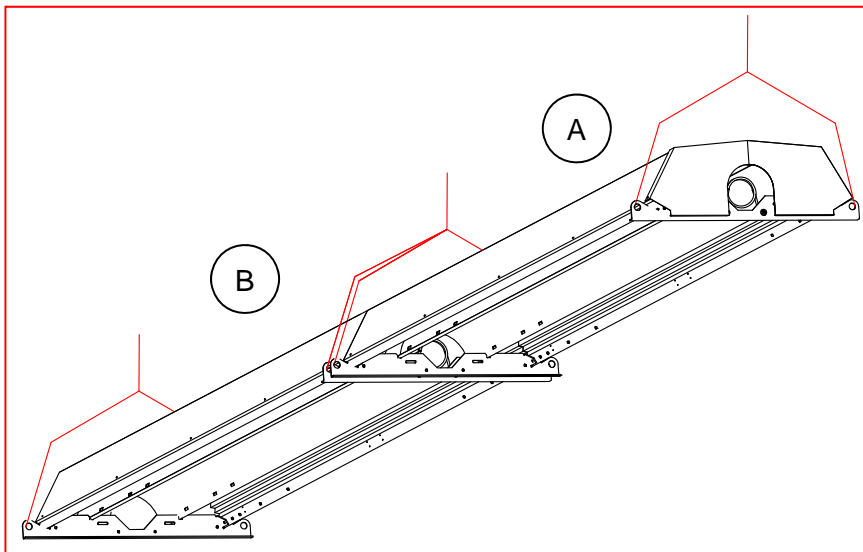

Suspend under the roof the converter Extractor side (H).
Follow the previous instruction for assembling this converter “extractor side” (H) to the previous converters.

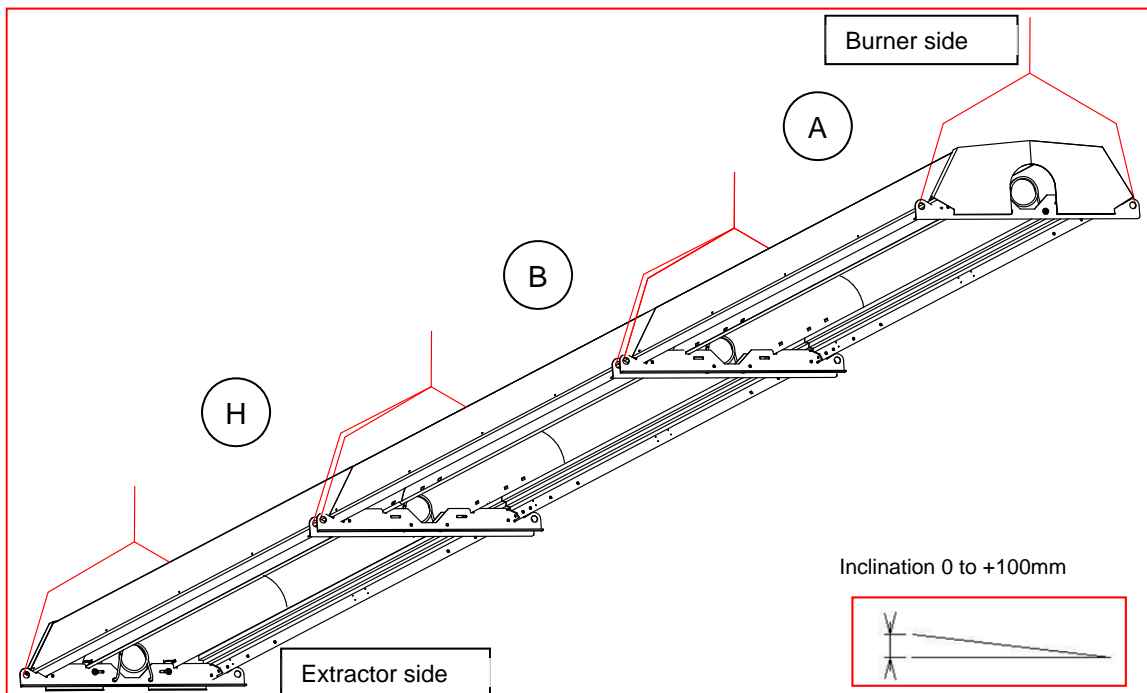

c/ Tubes preparation

The short tube (I) is equipped with a turbulator length 2 meters (M) on the extractor side and another turbulator of 1 meter (N) on the sleeve side.

The long tube (J) is equipped with only one turbulator of 1 meter (N) on the sleeve side.

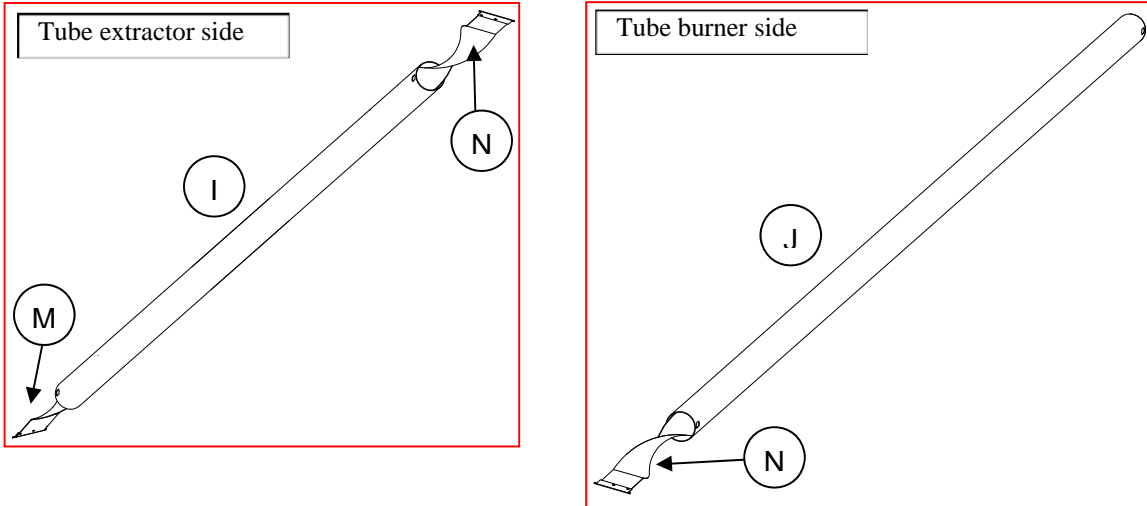

Detail of the position of the turbulator (M) inside the tube (I) on the extractor side.

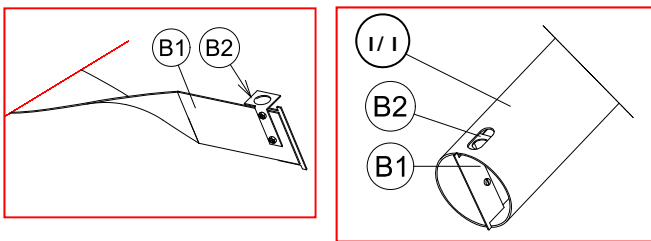

Mark	Designation
I	Short tube
B1	Turbulator
B2	Fixation part to be fixed only on the turbulator of length 2 meters, to be positioned in front of the oblong hole of the tube.

d/ Installation of the tubes :

Glide the tube (I) extractor side and glide the tube (J) burner side inside the fixing rings (L).

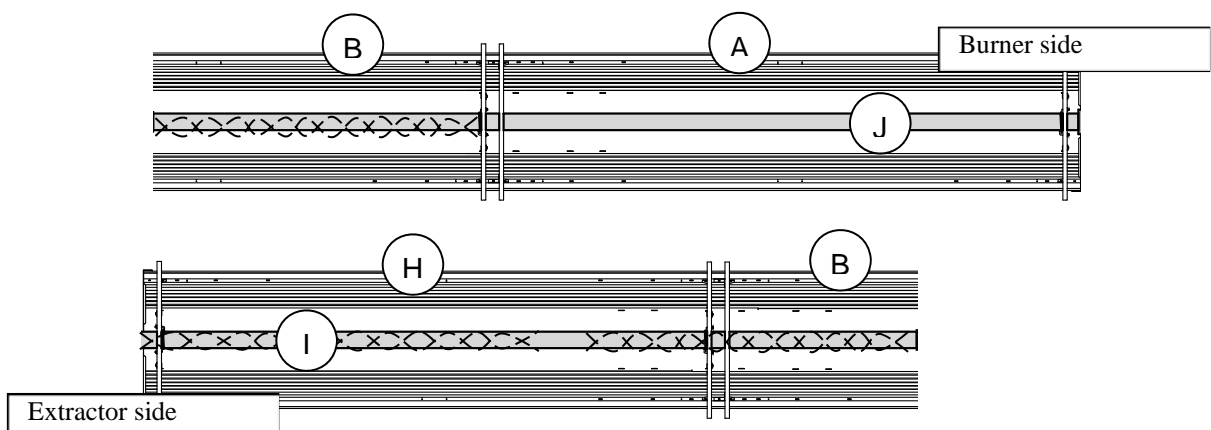
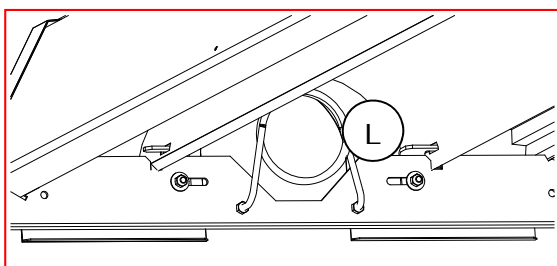

e/ Sleeves, Ubend and burner assembly.

Turn the tubes to have the oblong holes in lower position.

Put the sleeves (O) on the tube (I) and the tube (J).

Make certain that the screw (A2) goes through the elongated hole (A1) in the tube ensuring so that the moving tubes will come to a standstill!!!

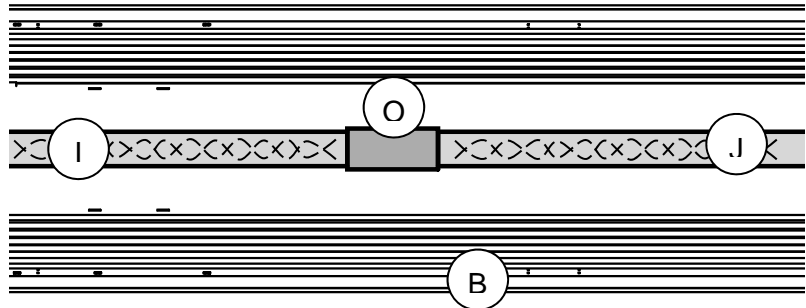
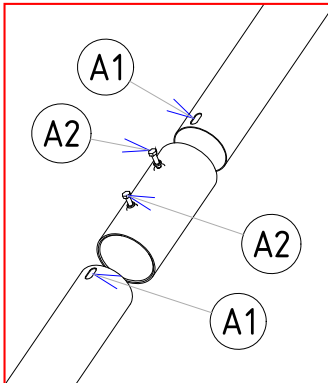

Turn the tubes on the previous position to have the oblong holes “burner side” and “extractor side” in the top position.

Install the burner block (P) on the tube.

Make certain that the screw (A2) goes through the elongated hole (A1) in the tube ensuring so that the moving burner block will come to a standstill!!!

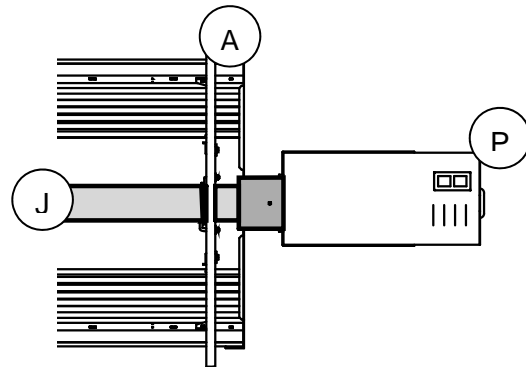
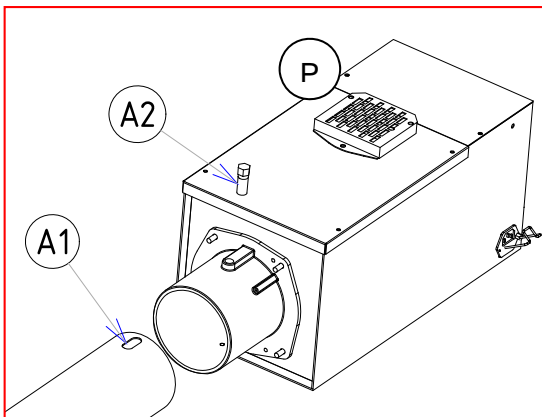

Install the extractor block (R) on the tube.

Make certain that the screw (A2) goes through the elongated hole (A1) in the tube ensuring so that the moving extractor block will come to a standstill!!!

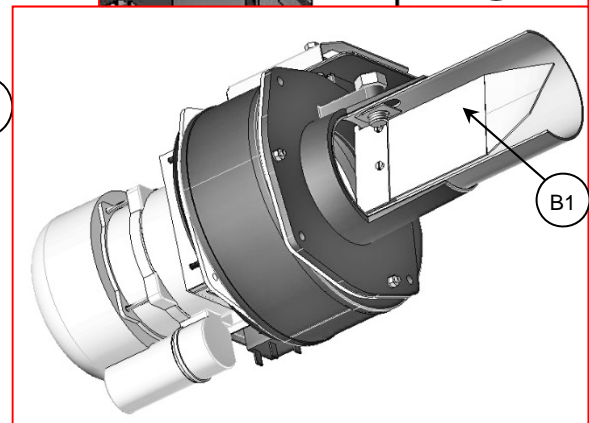
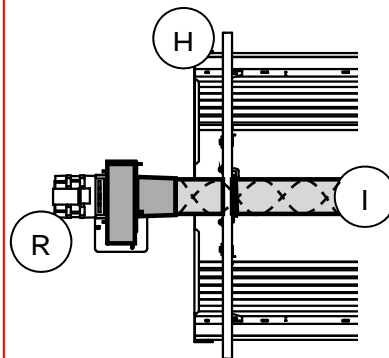
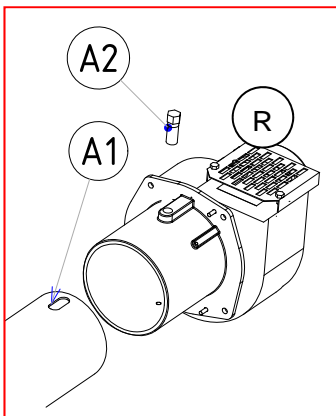
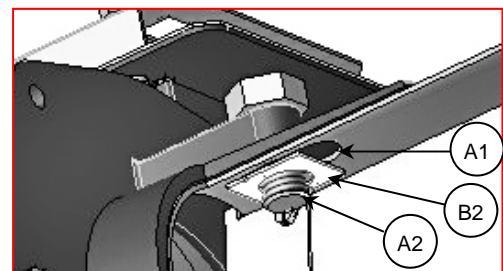

f/ Mounting of anti-rotation strap

Installing anti-rotation strap of burner unit.

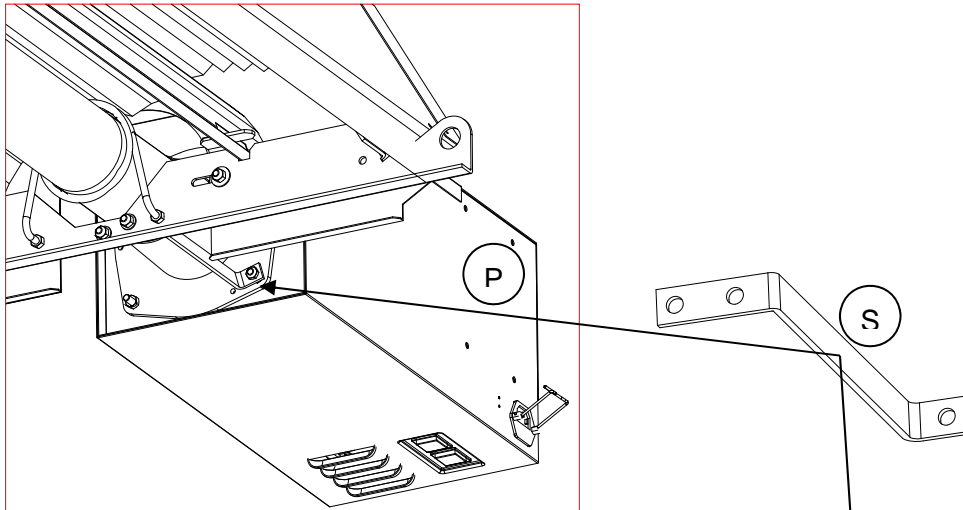

At burner unit side (P), attach the anti-rotation strap (S) to the screw surpassing the socket with the supplied lock nut (T).

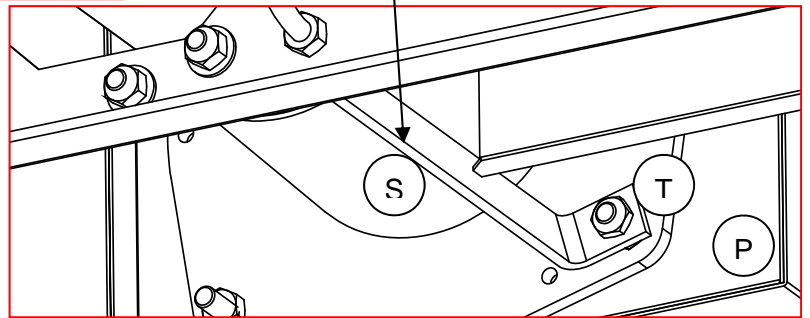

Crosswise (C), fix the anti-rotation strap (S) with the supplied 2 screws and nuts (U) applying the hereto provided 2 holes.

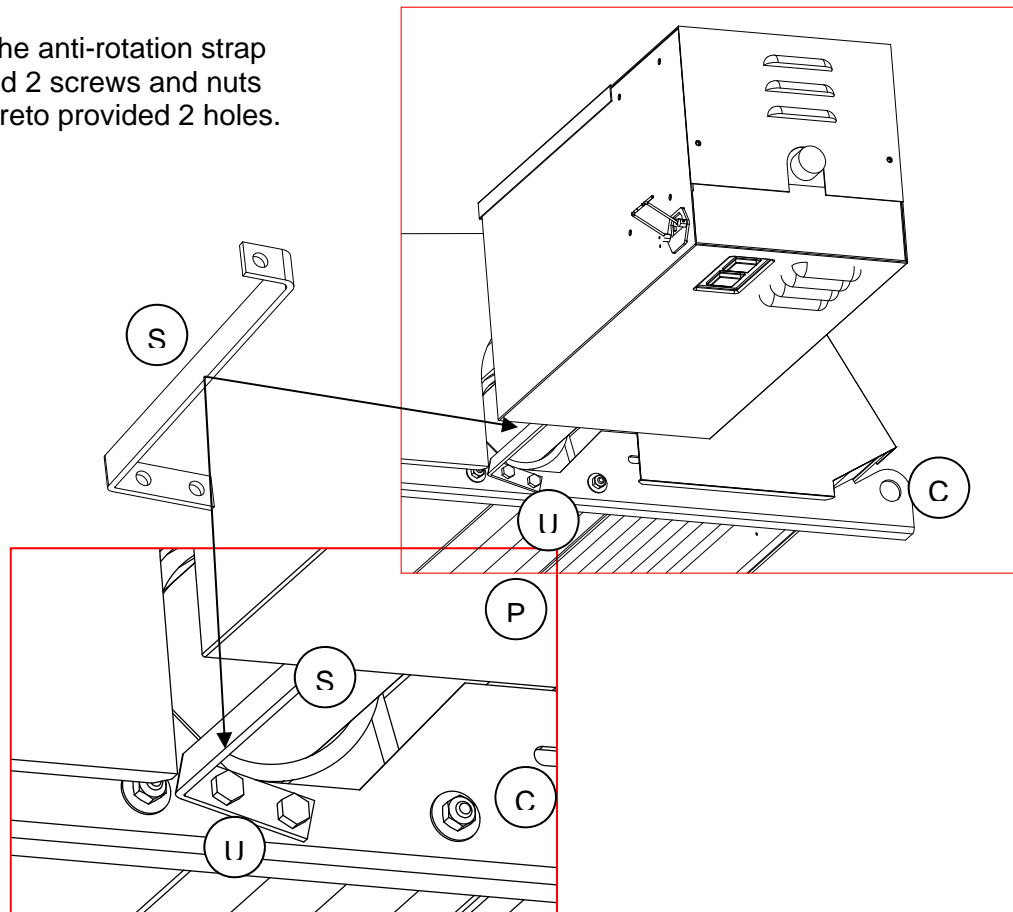

Top view, installed unit

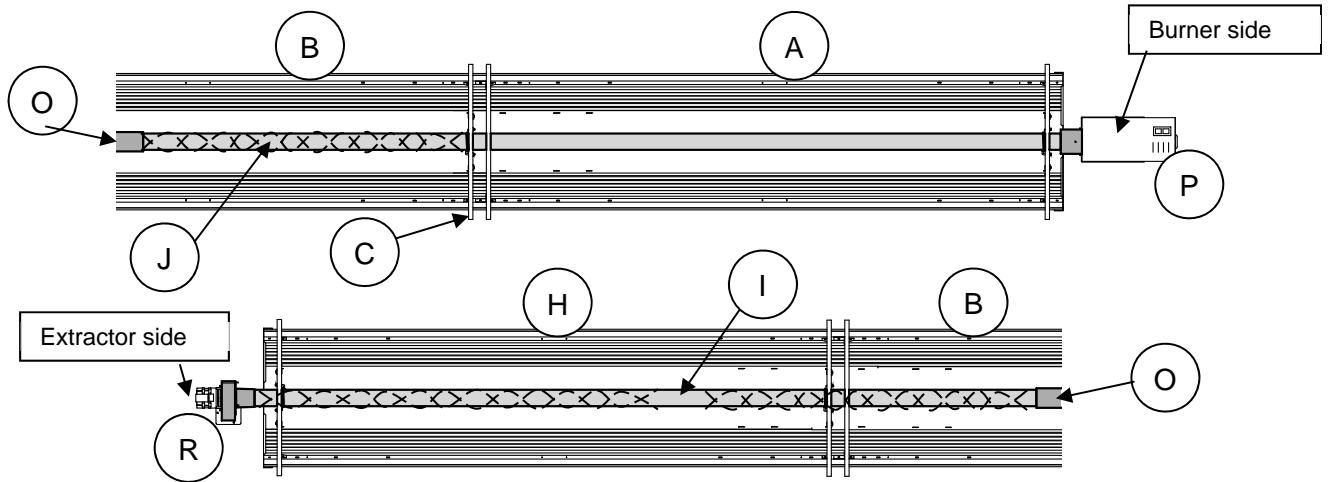

5-Suspension/Fixing

Suspend the radiant tubes by means of chains or cables of adequate length fixed to framework, under shores or portals, between pillars or against a wall. Optional fixing parts can be supplied.

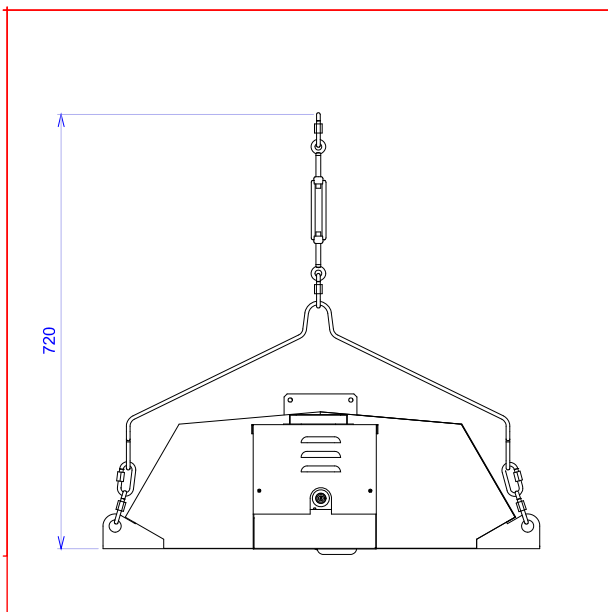

HORIZONTAL HANGING

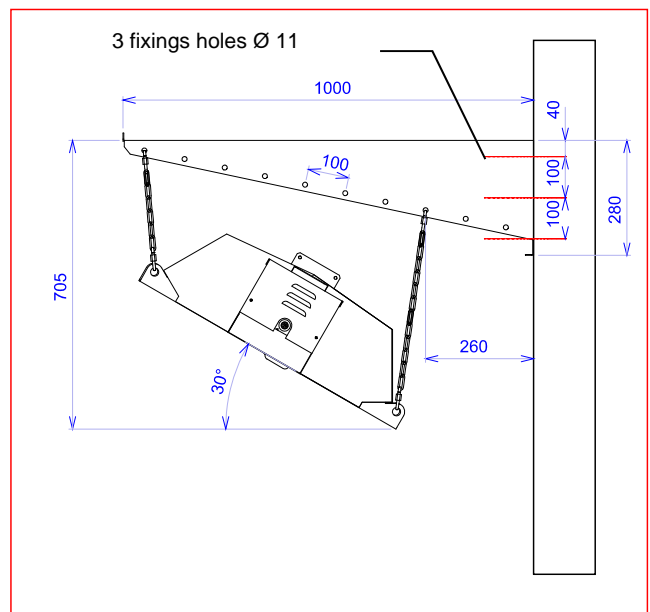

WALL HANGING

ATTENTION: For a good system efficiency, do not incline the unit up to 30°!!

Kit composition:

Model	Horizontal hanging	Wall hanging
	Reference of the kit	Reference of the kit
BTLH2R25	0340154	0340128

SAFETY INSTRUCTIONS

Care must be taken to install the anchor points perpendicular to the end supports.
The model BTLH2R25 contains 4 points of anchorage

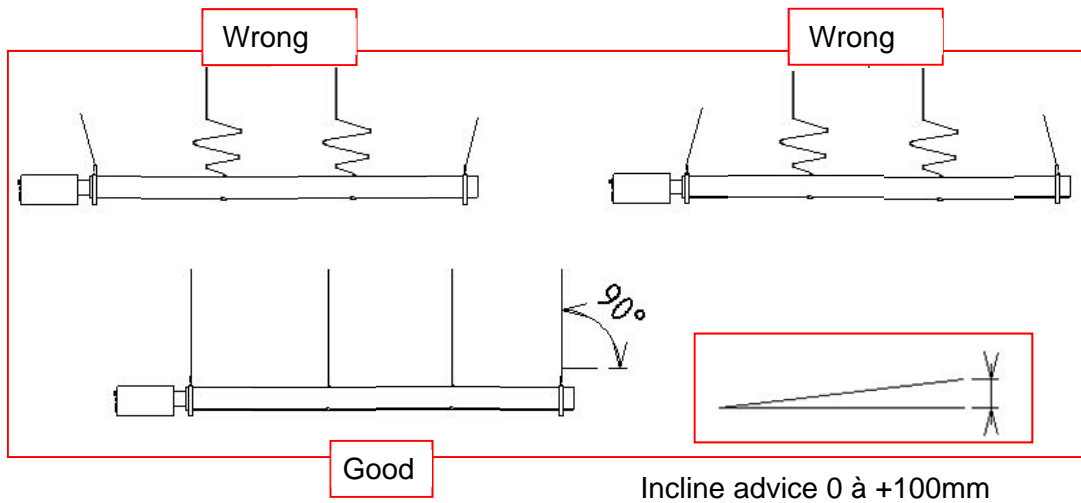

Very important:

Make use of a flexible suspension system enabling the expansion of the emitter tubes but avoiding extreme oscillations.

Wall supports, supplied on request take this instruction into account.

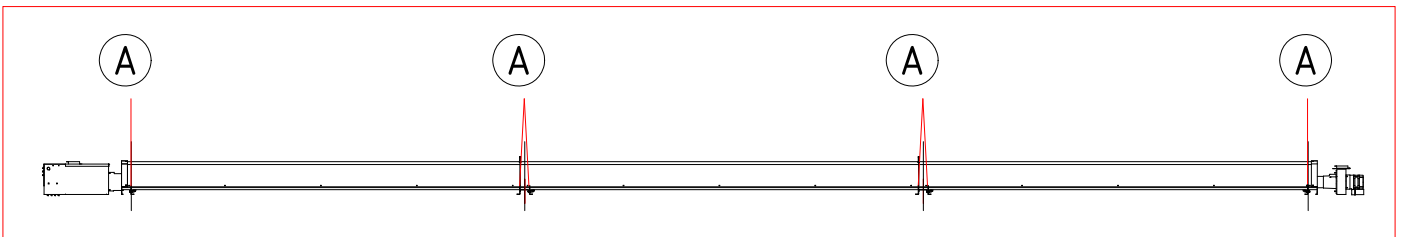

Mark	Designation
A	Required anchor points

6 Clearances

a/ Minimum distances towards unprotected combustible materials

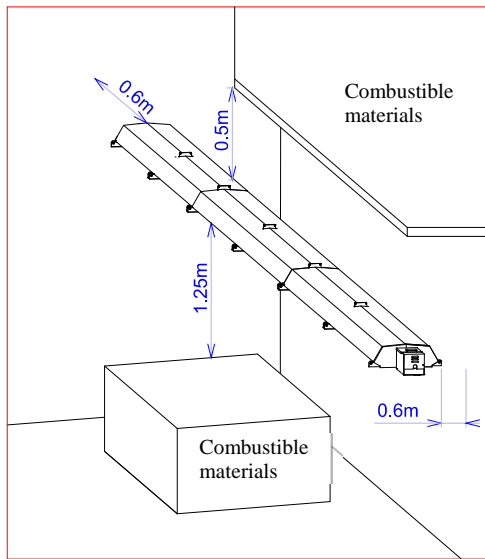

Units must be installed so that the minimum clearances towards unprotected combustible materials are maintained.

Furthermore, a thermal insulation is to be installed between the hanging support of the appliance and the material on which it is fixed, in case this material should be of a flammable nature.

CAREFUL: Refer to the rules in force.

b/ Recommended minimum height

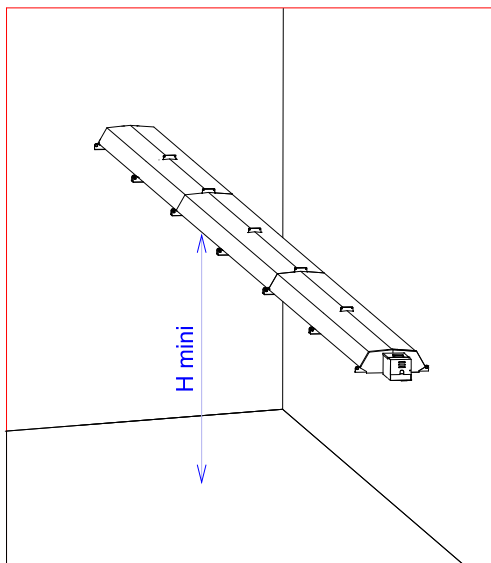

The minimal recommended mounting height in relation to the ground and in the case of global heating of a closed building if:

Device	Horizontal hanging	Wall hanging
BTLH2R25	4,10 m	3,50 m

Heights and mounting positions depend of the building structure and of the study implantation.

PARTICULAR CASES:

- 1) During the installation of an appliance above an overhead crane, provide if necessary the protection of the crab's motor and of electrical equipment by the means of an insulating sheet.
- 2) Avoid the installation of radiant tubes above bulky machines or stores which could prevent the diffusion of radiation towards the workers or users.
- 3) In the presence of lifting ramps (vehicle repair workshops) care should be taken not to fit the radiant tubes directly above these ramps. In fact, deterioration may occur to cars with bodies or covers which could stay on the high position of the ramp.
- 4) In the case of a workshop including pits or hidden zones, we cannot guarantee in these zones the same conditions of comfort as in the rest of premises.

7 Evacuation of combustion products

According to the type of building, to the insulation or to the air tightness of the building, there are 3 possible solutions:

Type A - Throwing out of the combustion products into the atmosphere

Type B - Individual fluting of each unit outside the building.

Type B - Appliances connected to a flue manifold system.

The following indications about the air renewal concern the good functioning of the appliances. Do not forget also to take into account the rules concerning people leaving in the heated premises

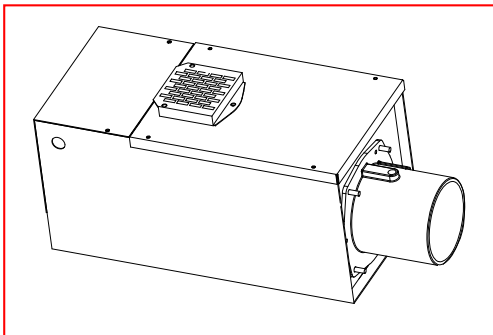

Burner block

TYPE A

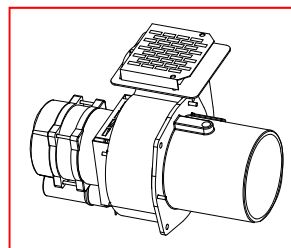

TYPE B

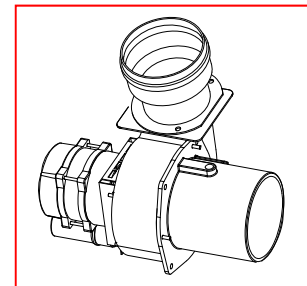

Extractor block

TYPE A

THROWING OUT OF THE COMBUSTION PRODUCTS INTO THE ATMOSPHERE

Nortek Global HVAC GAZ INDUSTRIE radiant tubes have a good combustion hygiene which has been controlled for the **CE** mark. However, they can only be installed and used in **well ventilated premises**.

Radiant tubes can be installed without evacuation ducts for the combustion products within the limits of the regulations in force. In that case, no modification has to be brought to the units which are already equipped with a protection grille.

Attention: In public buildings, the evacuation of flue gases is obligatory!

* However we draw your attention to the fact that combustion products emitted into the atmosphere can perceptibly modify the humidity level depending on the air change rate of the building.

In case products of combustion are not evacuated outdoors, ensure that the location where the unit is installed provides sufficient air to ensure a good functioning of the unit and the dilution of the combustion products by **10 m³/h per kW installed**.

Do not allow combustion products to come into contact with combustible materials.

CAREFUL: refer to the rules in force.

TYPE B

a / INDIVIDUAL FLUTING OF EACH UNIT OUTSIDE THE BUILDING

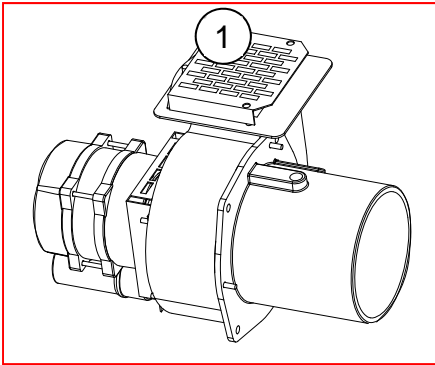

- Remove grill at exhaust pipe (1).
- And replace with connection piece Ø100 (2) for Ø97 tube.
- Do not use grill as protection for a flue pipe end.
- Air inlets must be sufficient in the premises in order to allow a good supply of the burner with air of combustion

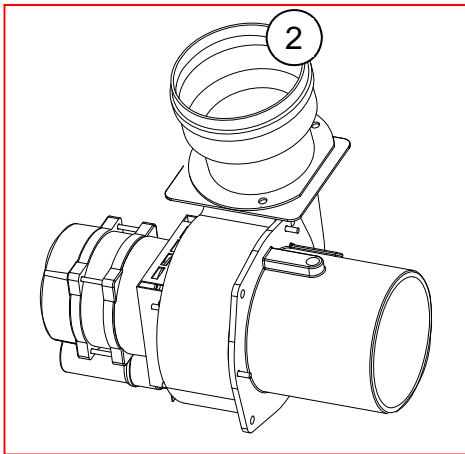

Plan for an external air flow of at least 1.75 m³/h per installed kW.

SAFETY INSTRUCTIONS CONCERNING THE INDIVIDUAL EVACUATION DUCT:

- No reduction of diameter can be accepted after the connection piece.
- It must be made out of stainless steel or aluminum with **smooth** and **rigid** duct.
- The evacuation must be realized according to the norms in force in each concerned country.
- The maximum length of the exhaust pipe do not be up than 8 meters + 3 bends 90° + 1 terminal (see on the spreadsheet hereunder).
- The duct must not include low point.
- Any accessory made out of plastic or PVC is absolutely prohibited.

	Air flow	Fumes temperature	Volumic flow	Massic flow
BTLH2R25	46 m ³ /h	183 °C	82 m ³ /h	60 kg/h

Flue system pipe lengths

Elbow 90°	2 m
Elbow 45°	1 m
Std protection cap against rain	2 m
1m rigid hose	1 m

CAREFUL: refer to the rules in force.

b / APPLIANCES CONNECTED TO A FLUE MANIFOLD SYSTEM

Very important:

The flow extracted on each appliance must be equivalent.

The installer will have to comply with the official texts of each country concerning mechanical evacuation and will have to get information from the competent national organizations about:

- 1) How to balance the network.
- 2) The controls and the different securities to put into operation.

Schematic diagram

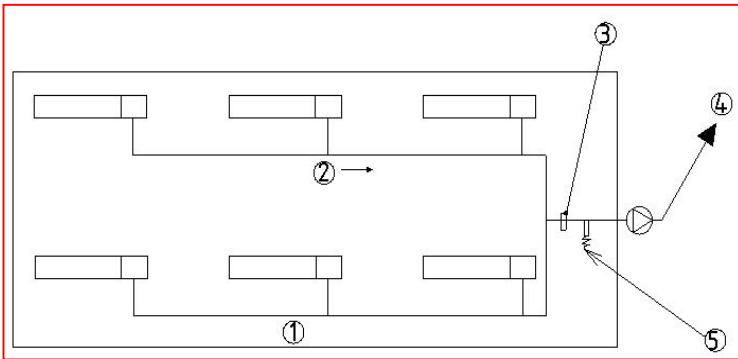

N°	Designation
1	Collector
2	Slope 4mm/m
3	Security pressure switch
4	Extraction fan
5	Condensation collector

It is necessary to take off the grille of flue outlet from the appliances and to replace it by a connection piece. Connect the top of the dilution piece to the collector with a flue tube and check that the connection of this duct is made on the side of the main duct (collector) and not from below. Place the dilution piece on the tube coming from the appliance and fix the 3 fixing parts by the means of screws or rivets.

Do not take off the screwed rod which is used as a thrust.

	Extracted flow dilution included
BTHL2R25	210 m ³ /h

Plan for that the air entry in the building is a minimum of 10m³/h per kW.

Details for the connection on collector

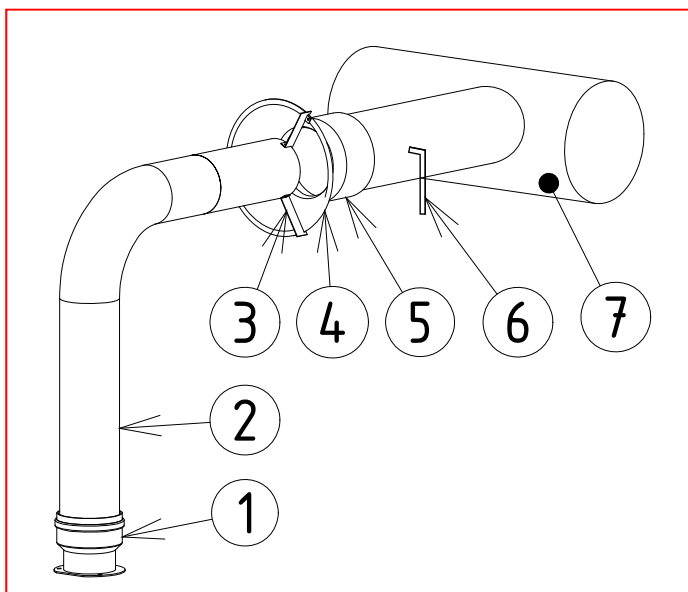

N°	Designation
1	Connection piece BTwin
2	Evacuating pipe Ø97
3	3 fixing parts at 120°
4	Dilution piece (Option supplied. on request)
5	Pipe Ø125 mini of collector
6	(Diaphragm or equalizing plate) if network has to be equalized
7	Collector (main duct) connected to a general extraction fan

8 Installation and connections (Gas and electricity)

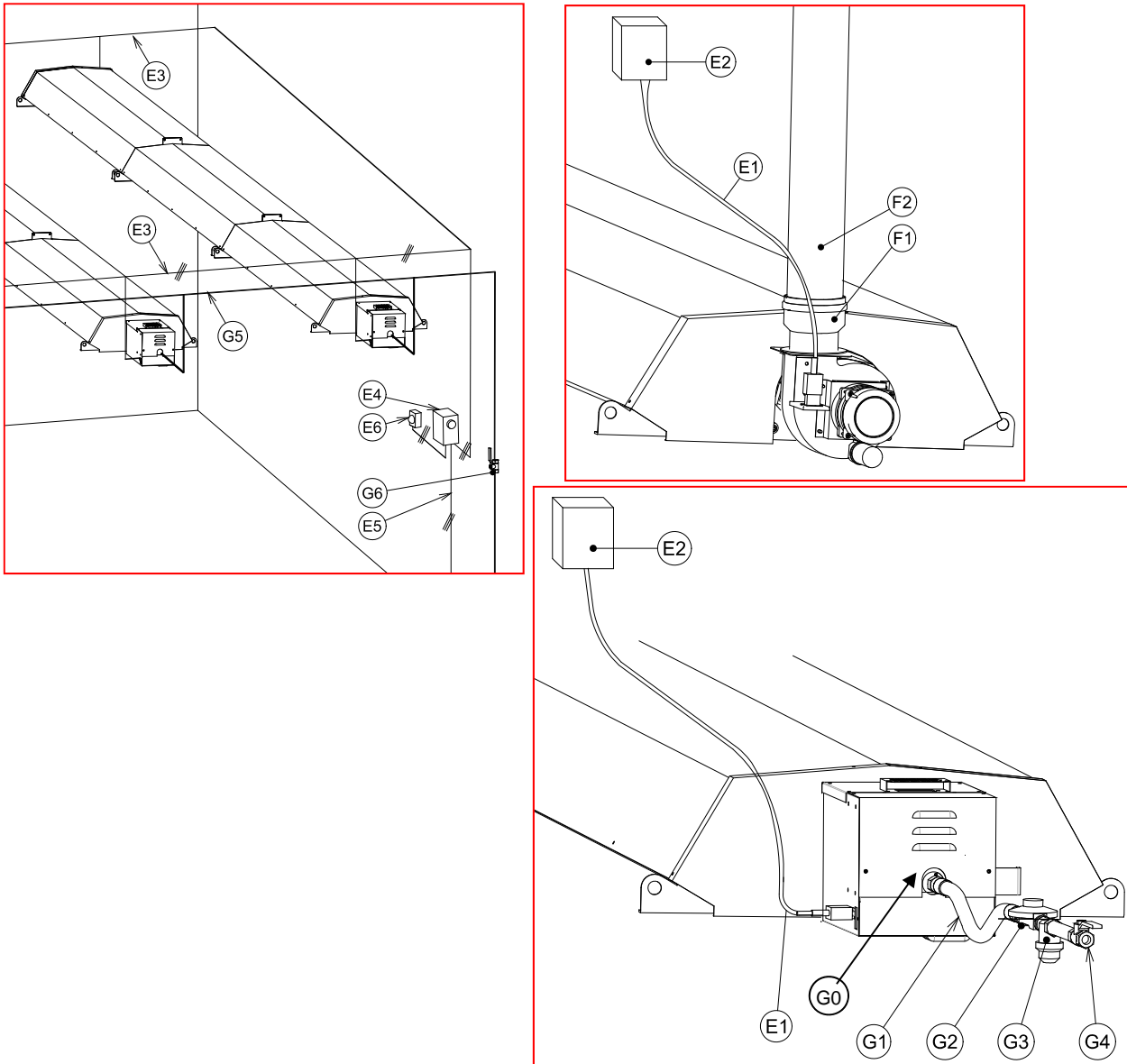

a/ Electrical connection

Mark	Designation
E1	Power cable (supplied with unit) L = 1,00m (3 x 0,75 mm ²)
E2	Junction box
E3	Power supply unit
E4	Power box (accessory Nortek Global HVAC)
E5	Power supply 230V 50Hz phase neutral earth
E6	Space sensor (accessory Nortek Global HVAC)

In case of electrical installation without neutral (or neutral of bad quality), an insulation transformer has to be foreseen in order to create an artificial neutral

CAREFUL: In no case should the electrical cable be located on stay on the converter or on the functional block of the appliance.

b/ Flue system

F1	Flue outlet connection Ø100 (accessory Nortek Global HVAC)
F2	Exhaust pipe Ø97 made of rigid material (not supplied)

c/ Gas connection

G0	Gas connection of the unit - G ¾" gas male
G1	Flexible pipe (special model, NF approved for public buildings) Ensure pipe is not liable to pressure load. (possible to replace with copper tube with min. Ø500mm)
G2	Pressure relief valve(installed upstream of each unit conform the gas supply pressure)
G3	Gas filter
G4	Cut-off valve ¼ turn per unit
G5	Gas pipe
G6	Main cut-off valve

d/ Option " Failure signal transmission "

This option allows the transmission of the failure signal (on each individual unit or per group of units) to a control panel or the GTC system.

To ensure safe working, the transmission of the failure signal happens by means of a dry contact controlled by a relay incorporated inside the unit (3).

In order to avoid undesirable shutdown at each ignition attempt, it is recommended to delay the failure signal of the control panel or GTC by 30 seconds.

The unit is delivered in standard version with a closed contact, if you want open one, you may ask us at the order.

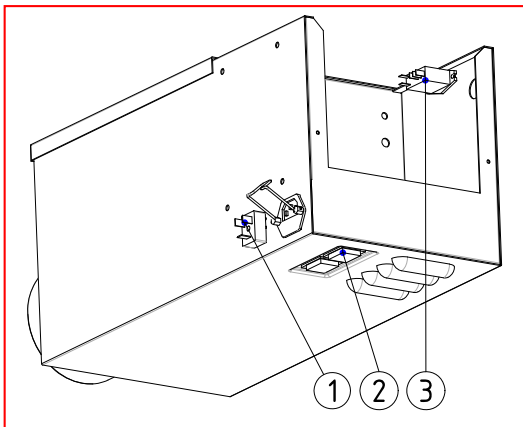

- (1) Lockout relay plug
- (2) Red light default
- (3) Lockout relay
- (4) Dry contact

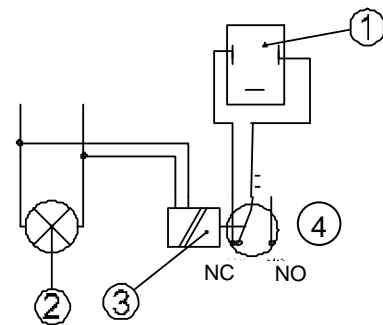

9 Temperature regulation

It is advised to foresee an automatic regulation according to the heating needs.

It is necessary to foresee a regulation per room or per zone.

The regulation occurs completely by the electric power supply of the units.

We advise the use of a resultant regulation for the complete installation, regardless global local or zonal heating. This regulation consists of an electronic regulator and a resultant sensor registering the energy radiated by the unit(s) and controlling the installation on the dry resultant temperature being a better comfort criterion than only the air temperature. The regulator contains a lowering of the occupation temperature: therefore is it necessary to use a dry contact from a clock or relay.

We advise to respect the instructions concerning the material and particularly:

- To position the sensor at about 1.5m from the ground between two appliances so that it receives a homogeneous radiation,
- To insulate the sensor from the wall on which it can be found in order to avoid the cold radiation of the wall through the interposition of an insulating material (glass wool, wood, etc.),
- The connection between sensor and regulator must be made out of armored cable or phone cable, 2 pairs.
- In any case, do not put these wires in the cable path which already contains many wires carrying energy

Material supplied by Nortek Global HVAC :

- Regulator with sensor Infracapt 20.10.
- Energystat, model Energystat 10 (1 zone), Energystat 12 (2 zones).
- Standard regulation box or specific on demand.

10 Programming

The clock index shall be placed so as to activate the start up about 30 minutes before the premises are occupied. The time lapse should be modified according to the inertia of the building and to the external temperature.

In the case of a very low external temperature, it is advised not to stop the heating during periods of inoccupation, but instead to simply reduce the temperature.

It is advised not to stop the heating during short interruptions in the use of premises.

11 Setting Up

- After resistance test for mechanical seals and cleaning of gas line:
- Clean the gas network.
- Check that electrical supply is correct.
- Check presence and correct state of the flue installation.

FUNCTIONNING CYCLE:

Appliances are regulated in factory and do not need any additional adjustment on site.

- As soon as the electrical supply is turned on, beginning of the pre-purge sequence of about 15 seconds (yellow and red control lamps light).

- Control of the negative pressure in the tube through differential pressure switch.

- When the negative pressure is sufficient, the ignition spark starts and the electromagnetic gas valve opens.

(Yellow lamp lights and red lamp turns on).

- When the sensor detects the flame, the ignition spark stops and the appliance functions as long as it is supplied in gas and in electricity.

- . If for whatever reason the flame is no longer detected, the electro valve closes and the unit goes to lockout.

(Yellow and red control lights turn on), then the appliance attempts another ignition and a second working cycle starts.

- In the event of a second ignition attempts without success, the unit again goes to lockout. The ignition sequence can only start again if the electric supply is cut and reconnected some seconds later.

- . While operating, only the yellow control light stays on.

- In case of technical problem, refer to paragraph 14 « Faults - possible causes ».

12 Maintenance

We recommend to check the appliance and the installation at least every year.

The checking must be made by skilled personal. A maintenance contract is advised.

CAREFUL: refer to the rules in force.

**CAREFUL: INSULATE GAS AND ELECTRICITY BEFORE ANY MAINTENANCE WORKS.
Check that access conditions and minimum distances are respected.**

List of necessary tools:

Brush, duster, paint brush, flue brush, vacuum cleaner, small case of electromechanical tools.

MAINTENANCE INSTRUCTIONS:

1) Emitter tubes

Clean up the external tubes with a metallic brush – remove the burner block to inspect the inner side. In case of a considerable dust deposit the tubes should be cleaned inside. Use hereto a bottlebrush with appropriate diameter or a dust aspirator.

2) Reflector:

Inspect inner side of reflector and if necessary clean with soft cloth and soap water. If necessary use soft metal wax.

3) Converter:

Clean by means of a brush.

Check if grooves are free of dirt and maintain a matt black tint ensuring good emission.

4) Extraction Turbine

Check that it turns freely and remove with a brush any accumulation of deposits that may exist on blades. Also remove dust from the fan volute.

5) Motor and cooling fan of motor axis:

Remove dust with compressed air (careful with the turbine over speed) and clean the aeration ears.

6) Ignition and security box:

Remove the electrical plate and remove dust if necessary.

Check that the control contact of negative pressure occurs correctly.

7) Gas tray set and mono-electrode

- Remove the electrode mounting panel. Disconnect the electric wires, inspect the electrode brush it and change it if necessary. Control the gap which must be 4 mm.
- Disconnect the electric wires of the electro valve.
- Take out the gas tray set by taking out the assembly screws on the face.
- Clean the injector, the burner and the burner head which must not be sooted up.
- Clean the electro valve and regulator filters and the cartridge filter.

8) Connection of pressure switch:

N°	Designation
1	Burner depression plug (green pipe)
2	Pressure plug on the air inlet

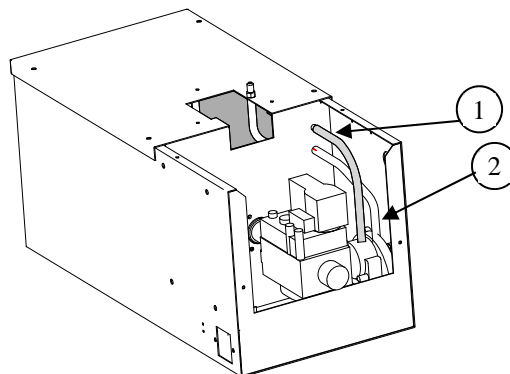

9) Evacuation duct:

Check and clean the fume ducts according to the rules in force.

REPLACEMENT OF PARTS:

Mono-electrode:

Dismantle the electrode carrier by unscrewing fixation screws. Change the set if necessary. The gap between the electrode and the earth electrode must be 4 mm.

Burner and injector:

Dismantle the electrode carrier. Unscrew the burner, unscrew the injector and change them if necessary. When the injector is dismantled, the joint must be replaced.

Ignition and security box

To take it out, take off the 4 fixation clips retaining it to the frontage panel, disconnect the connector and disconnect the HT ignition wire.

Pressure switch

Open the superior bonnet, disconnect and identify the cable terminals and take out the pressure switch from its support.

Fan Motor Group

Loosen the 4 nuts to easily remove the fan motor group.. To unfix the turbines, loosen the six-sided nut by means of an Allen key on the flat surface of the motor axle.

13 Gas change

- The gas conversion must be done by qualified technicians.
- When converting to another gas type, only the injector (5) must be changed.
- We refer to the table at page 5 showing the injector diameters to be respected.
- This table also indicates the inlet pressure and the pressure by injector that must be respected

Note: A conversion kit is available on demand (consult our price list for components). The kit comprises: injector, seal and gas label (must be adhered on the old label).

Successive checks to be done

- Check inlet pressure of working unit by means of a manometer connected to the pressure connection (2) (See also table at page 5).
- Check pressure at gas pressure connection (4).
- Adjust pressure at the injector by using the adjustment screw. (3) (See table on page 5).
- Fix appropriate gas label

Note: For the 3rd family gases 3+ PROPANE or BUTANE the regulator is blocked (3) (completely screwed in).

Mark	Designation
1	Electro valve inlet
2	Supply pressure intake (unblocked the screw in order to measure the pressure)
3	Pressure regulator (remove the brass plug terminal in order to access to the regulator screw)
4	Injector pressure intake (unblocked the screw in order to measure the pressure)
5	Brass injector (carved in mmx100)
6	Electro valve power supply

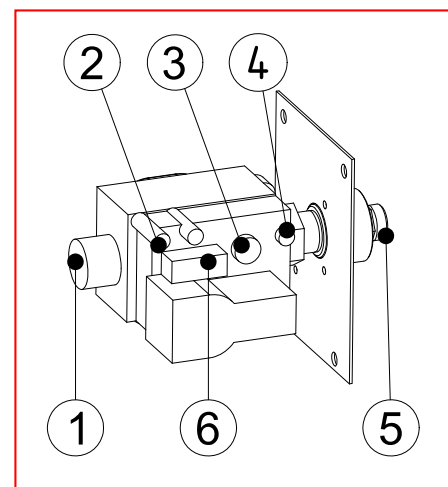

14 Faults – Possible causes - Solutions

Before any replacement of components internal to the appliances, be sure that:

- 1) The electrical supply of appliances is correct.
- 2) The gas is correctly supplied until the gas inlet of one or several appliances. (Gas filter cleaned).

FAULTS	POSSIBLE CAUSES	SOLUTIONS
the motor does not run (red and yellow lamps light on)	Impeller jammed Motor seized up or failed burnt fuse	Clean the fan casing Unseized and/or change change the fuse
the motor turns (red and yellow control lamps light on) but the appliance does not ignite	Clogged chimney Faulty motor Folded or disconnected pressure switch pipes Faulty ignition box Dirty impeller	Check - Clear To be cleaned or changed Replace them correctly To be changed To be cleaned (compressed air)
The pressure switch works correctly but there are no sparks	Cracked electrode Too big gap for ignition electrode Faulty control box	To be changed To be adjusted (4 mm ± 1 mm) To be changed
Sparks occur but the burner ignition does not occur. (yellow lamp lights on, red lamp lights off)	Faulty electro valve Ignition and security box Electrode out of position Default of gas supply	To be changed To be changed To be repositioned Clean filter and pipes
Ignition occurs but the appliance stops afterwards	Faulty flame control Inversion phase neutral Faulty ignition box	Check the ionization sensor and electrical connections (or quality of neutral) To be changed
Abnormal noise. Ignition problems	Disordered burner. Friction of turbines Motor bearing defect Coupling of emitter tubes	Check regulating. To be adjusted Change motor Correct and verify

15 Electrical Schema

INTERNAL

N°	Designation
1	Alim + Fuse
2	Red lamp
3	Yellow lamp
4	Electro valve
5	Pressure Switch
6	Electronic control box

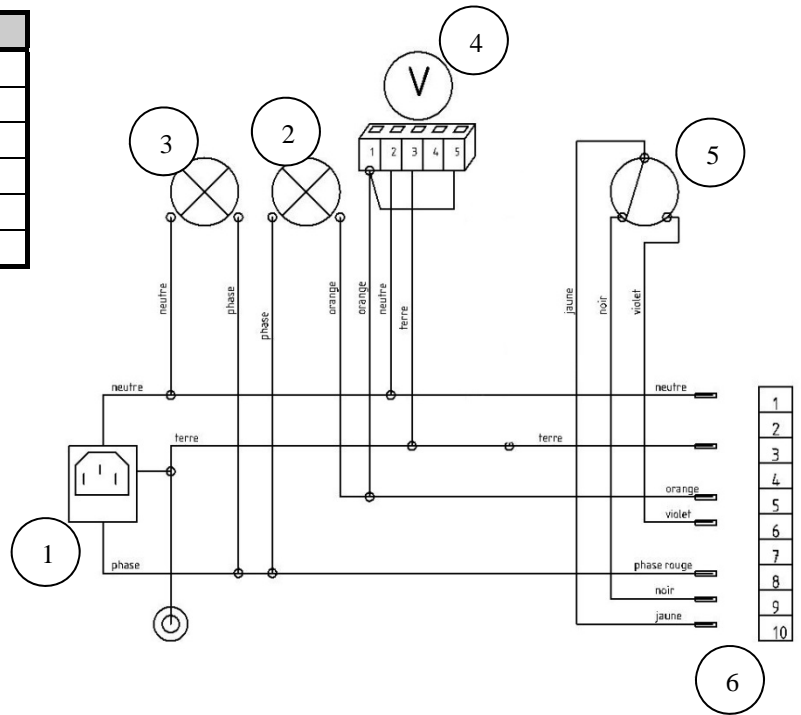

INTERNAL With isolating transformer

N°	Designation
1	Alim + Fuse
2	Red lamp
3	Yellow lamp
4	Electro valve
5	Pressure Switch
6	Electronic control box
7	Isolating transformer

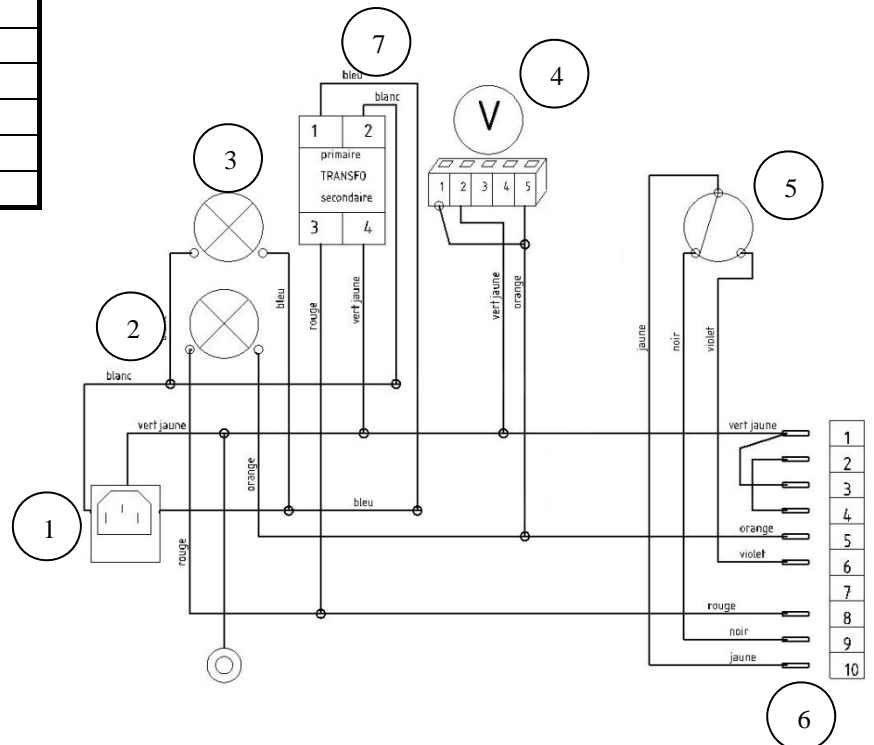

16 Options on request

Protection grille BTLH2R25	0340115
Isolating transformer	0240017
Return of defect : Normally closed	0240016

17 Parts

BTLH2R25

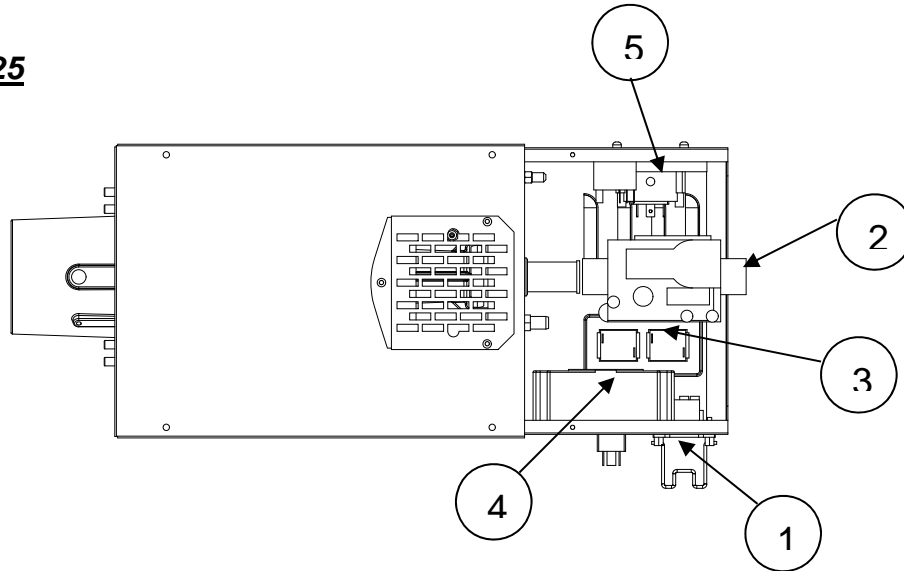

<p><u>2</u> Gas regulator</p>  <p>Ref : 10 21 210</p>	<p><u>4</u> Electric control box</p>  <p>Ref : 80 21 101</p>	<p>mono electrode assy</p>  <p>Ref : 10 30 016</p>
<p><u>1</u> Plug socket male and female</p>  <p>Ref : 02 80 217</p>	<p><u>3</u> Yellow inspection window</p>  <p>Ref : 10 25 243</p>	<p><u>3</u> Red inspection window</p>  <p>Ref : 10 25 244</p>
	<p><u>6</u> Fan Motor group BTLH2R25</p>  <p>Ref : 06 12 053</p>	<p><u>5</u> Pressostat BTLH2R25</p>  <p>Ref : 10 21 208-64</p>

Organisations which have the power to interfere before, during and after the setting up of appliances have to be consulted before the installation of the appliance in order to be informed about the norms and rules in force.

Nortek Global HVAC France S.A.S
Fabricant de matériel de chauffage
ZI de rosarge. | 230 rue de la dombes
Les Echets. | 01706 Miribel Cedex

Tel: 33 (0)4 72 26 50 50
Fax: 33 (0)4 72 26 50 40

gazindustrie@nortek.com
www.gazindustrie.eu